



Terry Arps, Mayor, Trustee One
Jerrod Davis, Trustee Two
Carla Caruthers, Trustee Three
Jeff Schwarzmeier, Vice-Mayor, Trustee Four
Valarie Braxton, Trustee Five

**BOARD OF TRUSTEES FOR THE TOWN OF LUTHER
TUESDAY, OCTOBER 10, 2023, AT 7:00 P.M.
LUTHER TOWN HALL
108 SOUTH MAIN STREET, LUTHER, OKLAHOMA 73054**

REGULAR MEETING AGENDA

Official action can only be taken on items which appear on the agenda. The Trustees may adopt, approve, ratify, deny, defer, recommend, amend, strike, or continue any agenda item. When more information is needed to act on an item, the Trustees may refer the matter to the Chairman or the Town Attorney, or back to a committee or recommending body. Under certain circumstances, items may be deferred to a specific later date or stricken from the agenda entirely.

1. Call to order
2. Invocation
3. Pledge of Allegiance
4. Roll Call
5. Determination of a quorum
6. Approval of the Consent Agenda,
 - a. Approval of the Board Minutes from the meetings of September 12 and 28, 2023.
 - b. Approval of Claims, including Payroll
 - c. Review and Approval of Treasurer's Report
7. Consideration of Items Removed from the Consent Agenda
8. Trustee Comments
9. Department Reports
10. Attorney's Report
11. **PUBLIC HEARING** to consider and take possible action to approve or deny an application for a Specific Use Permit (SUP) for property generally located at 16150 East Coffee Creek Road, Luther, Oklahoma, for purposes of placing a second single-family residence on a 21.00 acre tract of land. A copy of the proposed application is on file in the office of the Town Clerk at Luther Town Hall. The property is currently zoned A-1, Agricultural, and the legal description is as follows:

LUTHER TOWNSHIP 000 000 PT NW4 SEC 18 14N 1E BEG NW/C NW4 TH
E1460FT S628FT W1460FT N628FT TO BEG SUBJ TO ESMTS OF RECORD

Trustee One (Terry Arps)

12. Consideration, discussion and possible action to adopt Resolution 2023-05R, A RESOLUTION AUTHORIZING APPLICATION THROUGH THE ASSOCIATION OF CENTRAL OKLAHOMA

GOVERNMENTS (ACOG) FOR FINANCIAL ASSISTANCE FROM THE RURAL ECONOMIC ACTION PLAN (REAP) FUND, for a high-pressure sewer jetting machine.

13. Consideration, discussion and possible action to adopt Resolution 2023-06R, A RESOLUTION AUTHORIZING APPLICATION THROUGH THE ASSOCIATION OF CENTRAL OKLAHOMA GOVERNMENTS (ACOG) FOR FINANCIAL ASSISTANCE FROM THE RURAL ECONOMIC ACTION PLAN (REAP) FUND, for a sewer infrastructure project.

Trustee Two (Jerrod Davis)

14. Consideration, discussion, and possible action regarding Route 66 Revolving Fund projects.

Trustee Three (Carla Caruthers)

Trustee Four (Jeff Schwarzmeier)

Trustee Five (Valarie Braxton)

15. Consideration, discussion and possible action to choose a liaison for the Planning Commission.
16. **New Business:** In accordance with the Open Meeting Act, Title 25 O.S. 311.A.9 of the Oklahoma Statutes, new business is defined as any matter not known about or which could not have been reasonably foreseen prior to the time of posting the agenda.
17. **Citizen participation:** Citizens may address the Board during open meetings on any matter on the agenda prior to the Board taking action on the matter. On any item not on the current agenda, citizens may address the Board under the agenda item Citizen Participation. Citizens should fill out a Citizen's Participation Request form and give it to the Mayor. Citizen Participation is for information purposes only, and the Board cannot discuss, act or make any decisions on matters presented under Citizens Participation. Citizens are requested to limit their comments to two minutes.

18. **Adjourn.**

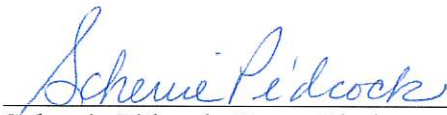

Scherrie Pidcock, Town Clerk



Agenda Posted Monday, October 9, 2023, at Luther Town Hall, via MailChimp, on the website at www.townoflutherok.com and on Facebook at The Town of Luther, prior to 7:00 pm.

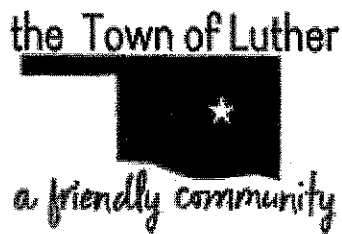

Terry Arps, Mayor, Trustee One
Jerrod Davis, Trustee Two
Carla Caruthers, Trustee Three
Jeff Schwarzmeier, Trustee Four
Valarie Braxton, Trustee Five

**BOARD OF TRUSTEES FOR THE TOWN OF LUTHER
TUESDAY, SEPTEMBER 12, 2023, AT 7:00 P.M.
LUTHER TOWN HALL
108 SOUTH MAIN STREET, LUTHER, OKLAHOMA 73054**

REGULAR MEETING MINUTES

1. Call to Order by Terry Arps.
2. Invocation by Jeff Schwarzmeier.
3. Pledge of Allegiance was led by Terry Arps.
4. Swearing In and Oath of Office of Valarie Braxton, newly appointed Town Board Trustee.-**Valarie Braxton took the Oath of Office and was sworn in by John Cobb.**
5. Roll Call by Terry Arps. Present were Terry Arps, Jerrod Davis, Carla Caruthers, Jeff Schwarzmeier and Valarie Braxton.
6. Determination of a quorum was made by Terry Arps.
7. Approval of the Consent Agenda,
 - a. Approval of the Board Minutes from the meetings of August 8 and 24, 2023.
 - b. Approval of Claims, including Payroll
 - c. Review and Approval of Treasurer's Report – Terry Arps made a motion to approve the Consent Agenda as presented, 2nd by Jerrod Davis. The Vote: All (5) Yes.
8. Consideration of Items Removed from the Consent Agenda. – None.
9. Trustee Comments – Terry Arps mentioned we have several upcoming projects. No other comments.
10. Department Reports – Terry Arps gave the Police and Code Enforcement Reports, Carla Caruthers gave the Fire Department Report.
11. Attorney's Report – Beth Anne Childs reported that she, court staff and police personnel met and discussed new laws going into effect on November 1, 2023, and that the Board of Trustees will have some new ordinances to consider at the next meeting.

Trustee One (Terry Arps)

12. Consideration, discussion and possible action to advise BancFirst to add Valarie Braxton to all Town of Luther and Luther Public Works Authority bank accounts. – Terry Arps made a motion to have Valarie Braxton added to all BancFirst accounts as written, 2nd by Jeff Schwarzmeier. The Vote: All (5) Yes.
13. Discussion of BancFirst Sweep account information. – Terry Arps relayed information regarding his conversation with BancFirst. Terry Arps made a motion to table the item until October 10, 2023, 2nd by Jerrod Davis. The Vote: All (5) Yes.

14. Consideration, discussion and possible action regarding a request for a lot split on a property located at 21705 N Luther Road, Luther, Oklahoma, 73054, with the legal description as follows: LUTHER TOWNSHIP BLK 000 LOT 000 PT NE4 SEC 16 14N 1E BEG 1327.27FT S & 746.44FT W OF NE/C NE4 TH N324.15FT W351.68FT N181.94FT W208.69FT S506.15FT E554.93FT TO BEG AKA TR A & A TR BEG 981.55FT S OF NE/C NE4 TH S345.72FT W746.44FT N324.15FT W351.68FT N181.94FT W208.69FT N157.47FT E872.47FT SLY213.6FT SELY401.89FT E43.16FT TO BEG AKA TR B COMBINED TRS CONT 17.19 ACRS MORE OR LESS – **Terry Arps made a motion to approve the lot split as recommended by the Planning Commission, 2nd by Jeff Schwarzmeier. The Vote: All (5) Yes.**

Trustee Two (Jerrod Davis)

Trustee Three (Carla Caruthers)

15. Consideration, discussion and possible action to authorize and fund a volunteer firefighter's EMR certification class in the amount of \$450.00. – **Carla Caruthers made a motion to authorize as written, 2nd by Terry Arps. The Vote: All (5) Yes.**
16. Consideration, discussion and possible action to enter into an agreement with Heartland Medical Direction in the amount of \$750.00. – **Carla Caruthers made a motion to enter into the agreement as written, 2nd by Terry Arps. The Vote: All (5) Yes.**
17. Consideration, discussion and possible action to order materials for Fire Prevention Week for the Pre-K through 4th grade students, at a cost of \$716.28 plus shipping. – **Carla Caruthers made a motion to authorize as written, 2nd by Valarie Braxton. The Vote: All (5) Yes.**
18. Consideration, discussion and possible action to purchase four (4) batteries for Unit 745 for an approximate total of \$900.00. – **Carla Caruthers made a motion to purchase the batteries as written, 2nd by Terry Arps. The Vote: All (5) Yes.**
19. Consideration, discussion and possible action to purchase 100 baffle balls for the water tank for Unit 745 at a cost of \$1,855.00. – **Carla Caruthers made a motion to purchase as written, 2nd by Jeff Schwarzmeier. The Vote: All (5) Yes.**

Trustee Four (Jeff Schwarzmeier)

Trustee Five (Valarie Braxton)

20. **New Business:** In accordance with the Open Meeting Act, Title 25 O.S. 311.A.9 of the Oklahoma Statutes, new business is defined as any matter not known about or which could not have been reasonably foreseen prior to the time of posting the agenda. – **None.**
21. **Citizen participation:** Citizens may address the Board during open meetings on any matter on the agenda prior to the Board taking action on the matter. On any item not on the current agenda, citizens may address the Board under the agenda item Citizen Participation. Citizens should fill out a Citizen's Participation Request form and give it to the Mayor. Citizen Participation is for information purposes only, and the Board cannot discuss, act or make any decisions on matters presented under Citizens Participation. Citizens are requested to limit their comments to two minutes. – **None.**

22. Adjourn. – Terry Arps made a motion to adjourn, 2nd by Jeff Schwarzmeier. The Vote: All (5) Yes.



Mintes transcribed by Scherrie Pidcock, Town Clerk

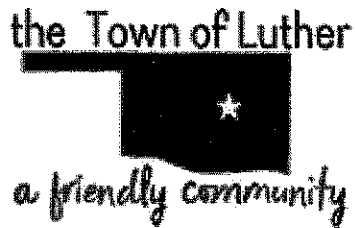

Terry Arps, Mayor, Trustee One
Jerrod Davis, Trustee Two
Carla Caruthers, Trustee Three
Jeff Schwarzmeier, Vice Mayor, Trustee Four
Valarie Braxton, Trustee Five

MINUTES

**BOARD OF TRUSTEES FOR THE TOWN OF LUTHER
THURSDAY, SEPTEMBER 28, 2023, AT 6:30 P.M.
LUTHER TOWN HALL
108 SOUTH MAIN STREET, LUTHER, OKLAHOMA 73054**

1. Call to order by **Terry Arps.**
2. Invocation by **Jeff Schwarzmeier.**
3. Pledge of Allegiance was led by **Terry Arps.**
4. Roll Call by **Terry Arps.** Present were **Terry Arps, Jerrod Davis, Carla Caruthers, Jeff Schwarzmeier and Valarie Braxton.**
5. Determination of a quorum was made by **Terry Arps.**
6. Trustee Comments - **None.**

Trustee One (Terry Arps)

7. Consideration, discussion and possible action to hire one (1) Police Officer as a School Resource Officer. – **Terry Arps made a motion to hire Randy Nailon as Police Sergeant and the SRO officer at Step 2, 2nd by Jeff Schwarzmeier. The Vote: All (5) Yes.**
8. Consideration, discussion and possible action to hire one (1) Police Officer as a Patrol Officer. – **Terry Arps made a motion to hire Jason Hall as a Master Patrol Officer Step 4, 2nd by Jeff Schwarzmeier. The Vote: All (4) Yes.**
9. Consideration, discussion and possible action to settle an accident claim with OMAG for the 2016 Ford K9 Unit, VIN 7408, in the amount of \$12,300.00 less deductible of \$500.00 for a total settlement of \$11,800.00. – **Terry Arps made a motion to settle the claim as written, 2nd by Jeff Schwarzmeier. The Vote: All (5) Yes.**
10. Consideration, discussion and possible action to surplus the following motorcycles:
2013 BMW RT 1200P VIN WB1044002DZW22089
2013 BMW RT 1200P VIN WB1044009DZW22087
2013 BMW RT 1200P VIN WB1044006DZW22628
2013 BMW RT 1200P VIN WB1044005DZW22085
2013 BMW RT 1200P VIN WB1044004DZW22627
2013 BMW RT 1200P VIN WB1044000DZW22088
Terry Arps made a motion to surplus the six (6) referenced motorcycles, 2nd by Jeff Schwarzmeier. The Vote: All (5) Yes.
11. Consideration, discussion and possible action to waive formal competitive bidding and purchase a fully equipped 2016 Ford Explorer with 70K miles in the amount of \$5,795.00, plus the trade of six

(6) police motorcycles, to replace the Ford Explorer K9 Unit. – **Terry Arps made a motion to purchase the 2016 Ford Explorer as written, 2nd by Jerrod Davis. The Vote: All (5) Yes.**

12. Consideration, discussion and possible action to accept the resignation of Kasey Wood from the Parks Commission and advertise for a new member to the Commission. – **Terry Arps made a motion to accept the resignation of Kasey Wood, 2nd by Jeff Schwarzmeier. The Vote: All (5) Yes.**
13. Consideration, discussion and possible action to accept the resignation of Maci Hoskins from the Police Department. – **Terry Arps made a motion to accept the resignation of Maci Hoskins effective immediately, 2nd by Jeff Schwarzmeier. The Vote: All (5) Yes.**
14. Consideration, discussion and possible action to choose which projects to make application for ACOG REAP grants. – **Terry Arps made a motion for each member of the Board of Trustees to give Scherrie Pidcock their top project choice on September 29, 2nd by Jeff Schwarzmeier. The Vote: All (5) Yes.**

Trustee Two (Jerrod Davis)

15. Consideration, discussion and possible action to set a date for trick or treat night and other possible related Halloween activities. – **Jerrod Davis made a motion to designate October 31, 2023, for Trick or Treat night and allow Trunk or Treat on Main Street for those who want to participate, 2nd by Valarie Braxton. The Vote: All (5) Yes.**

Trustee Three (Carla Caruthers)

Trustee Four (Jeff Schwarzmeier)

Trustee Five (Valarie Braxton)

16. Consideration, discussion and possible action to use the meeting/court room for various L'Whotherville activities, providing there is a Town employee or Trustee present at all times. – **Valarie Braxton made a motion to allow use of the meeting room as written, 2nd by Terry Arps. The Vote: All (5) Yes.**
17. Consideration, discussion and possible action for installation of a handicap ramp on the north end of Main Street, on the east side where the stairs are located. – **Valarie Braxton made a motion to explore the possibility of ramp installation, with possible help from Oklahoma County, 2nd by Carla Caruthers. The Vote: All (5) Yes.**
18. Citizen participation: Citizens may address the Board during open meetings on any matter on the agenda prior to the Board taking action on the matter. On any item not on the current agenda, citizens may address the Board under the agenda item Citizen Participation. Citizens should fill out a Citizen's Participation Request form and give it to the Mayor. Citizen Participation is for information purposes only, and the Board cannot discuss, act or make any decisions on matters presented under Citizens Participation. Citizens are requested to limit their comments to two minutes. – **Bruce Freeman was present and inquired about the status of Cox Communication's progress in Luther.**
19. Adjourn. – **Terry Arps made a motion to adjourn, 2nd by Jeff Schwarzmeier. The Vote: All (5) Yes.**





SEPTEMBER 2023

Luther Police Department Stats

Total calls for service

277

TYPES OF CALLS

- Reckless Driver-3
- Misc. Police Work- 28
- Follow up- 3
- Animal complaint-2
- Extra patrol- 18
- Medical Call- 3
- Motorist Assist- 2
- Disturbance- 4
- Agency Assist- 16
- Burglary- 1
- Livestock- 1
- Information Report- 2
- Suspicious Activity- 3
- Suspicious Person- 1
- Property Damage- 1
- Assault- 1
- Alarm- 1
- Theft/Larceny- 1
- Accident w/injury- 1
- Fire call-1
- Runaway-1

TRAFFIC
September 2023

Traffic Stops 102
Citations Issued 56
Warnings 51

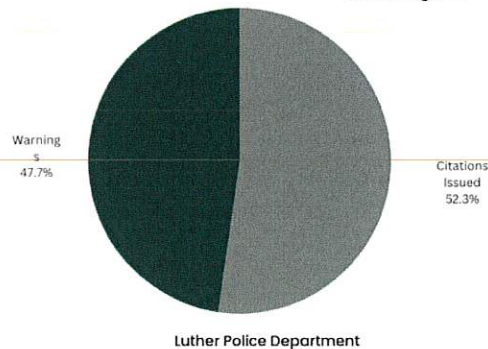

ARRESTS
Sept 2023

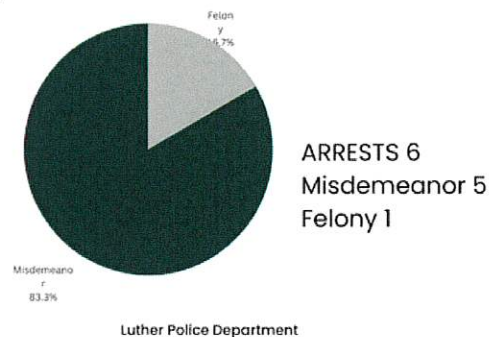

Luther Police Chief Johnny Leafly
Luther Police Department
Desk phone (405) 697-1926



CODE ENFORCEMENT MONTHLY REPORT

SEPTEMBER 2023

ACTIVITY:

Cases Opened: Contacted 22 Residents.

17 Trash and tall weeds, Debris and Trees contacts were made.

14 Have been Corrected.

6 Showing Progress.

1 Warnings Issued.

5 Courtesy Notices issued.

Highlights.

Have spent time researching three properties on N Ash between feed store and 66. One owner agreed to mow lot S of grow facility.

North of feed store talked to owner for quite some time with a refusal to mow. Hope on this property possible new owner.

Property North of Sonic letter will need to go out.

Daniel McClure

Code Enforcement Officer

scheduled meeting.

- 4. If your case is approved, you may seek permit approval to use the property in accordance with the Town Board's conditions. If your case is denied, you may appeal to the Board of Adjustment within 10 days.

The above information is for general guidance only. For further details and/or information, please call the Town of Luther at (405) 277-3833.

Your hearing date will be set once the application is received.



PO Box 56, 108 South Main Street - Luther, Oklahoma 73054 - (405) 277-3833 - FAX (405) 277-9965 - www.townoflutherok.com

Application for Specific Use Permit

Address or General Location:

16150 East Coffee Creek Road

Present Zoning: Agriculture Record Owner:

Janet J McLain Revocable TRUST

Legal description of tract under application (If described by metes and bounds, attach plat of survey):

Luther township Block 000 Lot 000 Pt NW 4 Sec 18
14N 1E BEG NW/4 NW 4 THE 1460 FT
S 628 FT W 1460 FT N 628 FT TO BEG SUBJ
TO ESTIMATES ON RECORD.

★ See exhibit A

If applicant is other than owner, please indicate interest (purchaser, lessee, agent for, other):

N/A

Are there any private or deed restrictions controlling use of tract? If yes, explain:

Bill advertising and sign charges to:

Address: 16150 East Coffee Creek Rd City:
Luther State: OL Zip: 73054

Phone: 405.823.7855

I do hereby certify that the information herein submitted is complete, true and accurate.

Signature: Janet J McLain, trustee for Janet J McLain Trust Date: _____

Print Name: Janet J McLain Phone: 405.823.7855

Address: 16150 East Coffee Creek Rd City: Luther State: OK Zip: 73054

Email: janetcooks59@gmail.com

General Description of Property

Size in acres or square feet: 916,880 sq. ft

Current Use: Agriculture/Residential

Topography (flat, rolling hills, levee, etc.): Approximately 15 acres flat, then wooded and up hill towards North Indian Meridian.

Frontage Road: East Coffee Creek Rd.

Identify structures and improvements on the property:
Approximately 500 sq ft "hunter's shed"
Approximately 640 sq ft single wide mobile home.

Town water? YES / NO
Town Sewer? YES / NO

Identify the use(s) intended for the subject property:
Residential — new home construction

Describe the benefits, if any, of your proposed use to the adjacent properties and/or to the Town of Luther:

Increased Property Values. Via new home construction as matching in existing area.

Identify how well suited the subject property is for your proposed use. (Cite such advantages as topography, foliage, soil, drainage, access, distance to centers of population, availability of utilities, etc.) Explain:

Large acreage with plenty of area for a larger home. Utilities already available.

Explain how the proposed change in use will affect the road system serving your area:

No Road change as we already have a mobile home on the property.

Give an estimated traffic count (average daily trips) for the proposed use. How will the potential traffic resulting from the increased use or activity be controlled?

No traffic change as we already live on the property.

Is the proposed use compatible to surrounding permitted uses and the existing development pattern? Explain:

Yes. Larger homes are all around the property.

How will the proposed use be detrimental to property in the same zone or vicinity? (Identify any adverse effects and explain measures you would propose to minimize these effects.) Explain:

No adverse effects as the new construction will be more valuable than other homes in the area.

NOTICE: APPLICATION FEE IS \$100.00 + ANY COSTS INCURRED BY THE TOWN FOR THE PROCESSING OF THE APPLICATION

Exhibit B (attached): adjacent neighbors
Exhibit C (attached): site plan

DO NOT WRITE BELOW THIS LINE - FOR OFFICE USE ONLY

Application received by: _____

Date: _____

Tract Acreage: _____ Public Hearing Date: _____

Application Number: _____ Section: _____

Township: _____

Range: _____ Present Zoning: _____ Fee

Receipt Number: _____

Show all existing buildings on application for addition or outbuildings: also setback delineations. Please show nearest cross streets (county maintained) and any private roads to the location for any unplatted area.

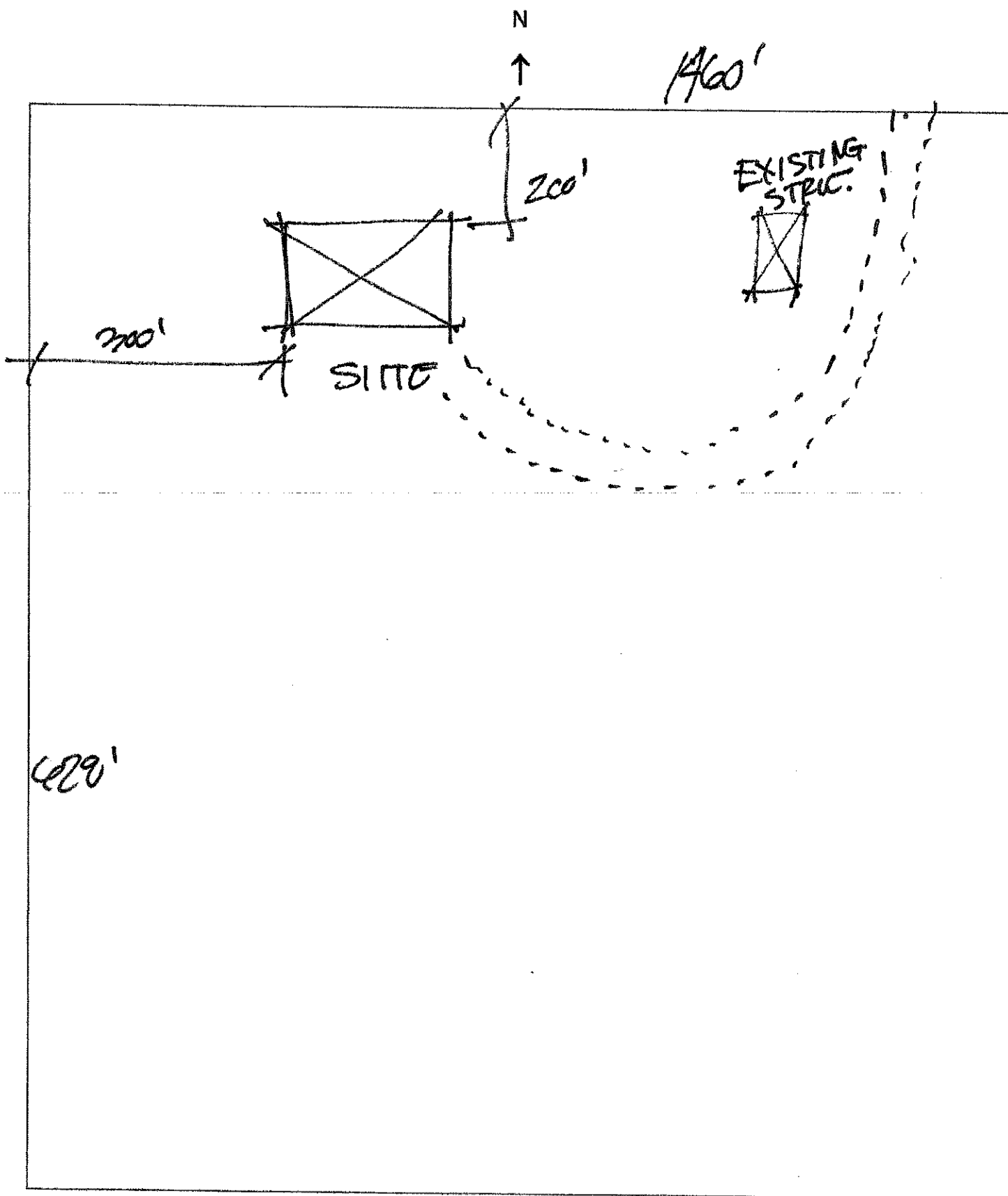

EXHIBIT "A"
Legal Description

For Tax Map ID(s): 264183000

Part of the Northwest quarter (NW/4) of Section Eighteen (18), Township Fourteen (14) North, Range One (1) East of the I.M., Oklahoma County, Oklahoma, and being more particularly described as follows: Beginning at the NW corner of said Northwest quarter (NW/4); Thence S 0°23'53" E along the West line of said NW/4 for a distance of 328.00 feet; Thence N 89°27'15" E and parallel with the North line of said NW/4 for a distance of 1460.00 feet; Thence N 0°23'53" W for a distance of 328.00 feet to a point on the North line of said NW/4; Thence S 89°27'15" W along said North line for a distance of 1460.00 feet to the Point or Place of Beginning.

AND

Part of the Northwest quarter (NW/4) of Section Eighteen (18), Township Fourteen (14) North, Range One (1) East of the I.M., Oklahoma County, Oklahoma, and being more particularly described as follows: Commencing at the NW corner of said NW/4; Thence S 0°23'53" E along the West line of said NW/4 for a distance of 328.00 feet to the Point or Place of Beginning; Thence continuing S 0°23'53" E along said West line for a distance of 300.00 feet; Thence N 89°27'15" E and parallel with the North line of said NW/4 for a distance of 1460.00 feet; Thence N 0°23'53" W for a distance of 300.00 feet; Thence S 89°27'15" W and parallel with the North line of said NW/4 for a distance of 1460.00 feet to the Point or Place of Beginning

☆ Owner: MCLAIN JANET J REV TRUST

Account Number: R264183000

Physical Address: UNKNOWN

Owner Name1: MCLAIN JANET J REV TRUST

Owner Name2:

Owner Name3:

Mailing Address1: 16150 NE 220TH ST

City: LUTHER

State: OK

Zip Code: 73054

Tax District: 103

Tax District Name: Luther #3

[View Assessor's Page](#)

[Add to Results](#)

[View Additional Details](#)

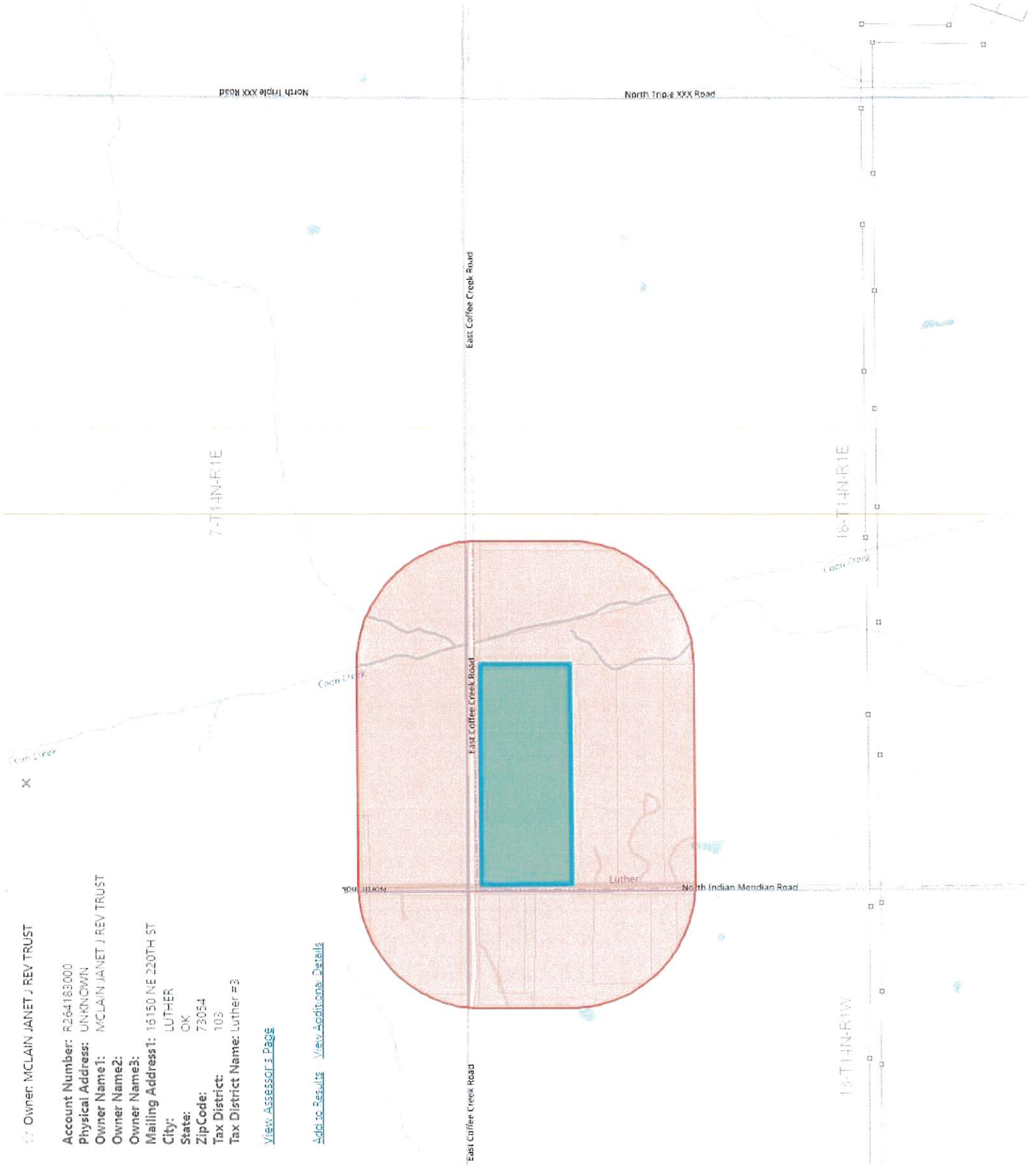

10' UP

N. Indian Meridian

S 00°23'53" E 628.00'

⑤ 33' Statutory Right-of-Way

Set 1/4" Nail w/Meshor
Hale & Assoc. CA 819"

Set 3/8" Iron Bar w/Cap
Hale & Assoc. CA 819"
(Typical)

Found 3/8" Iron Bar
3.67' S. & 0.49' W.

Overhead Electric Lines
are not located within an Easement

Coffee Creek

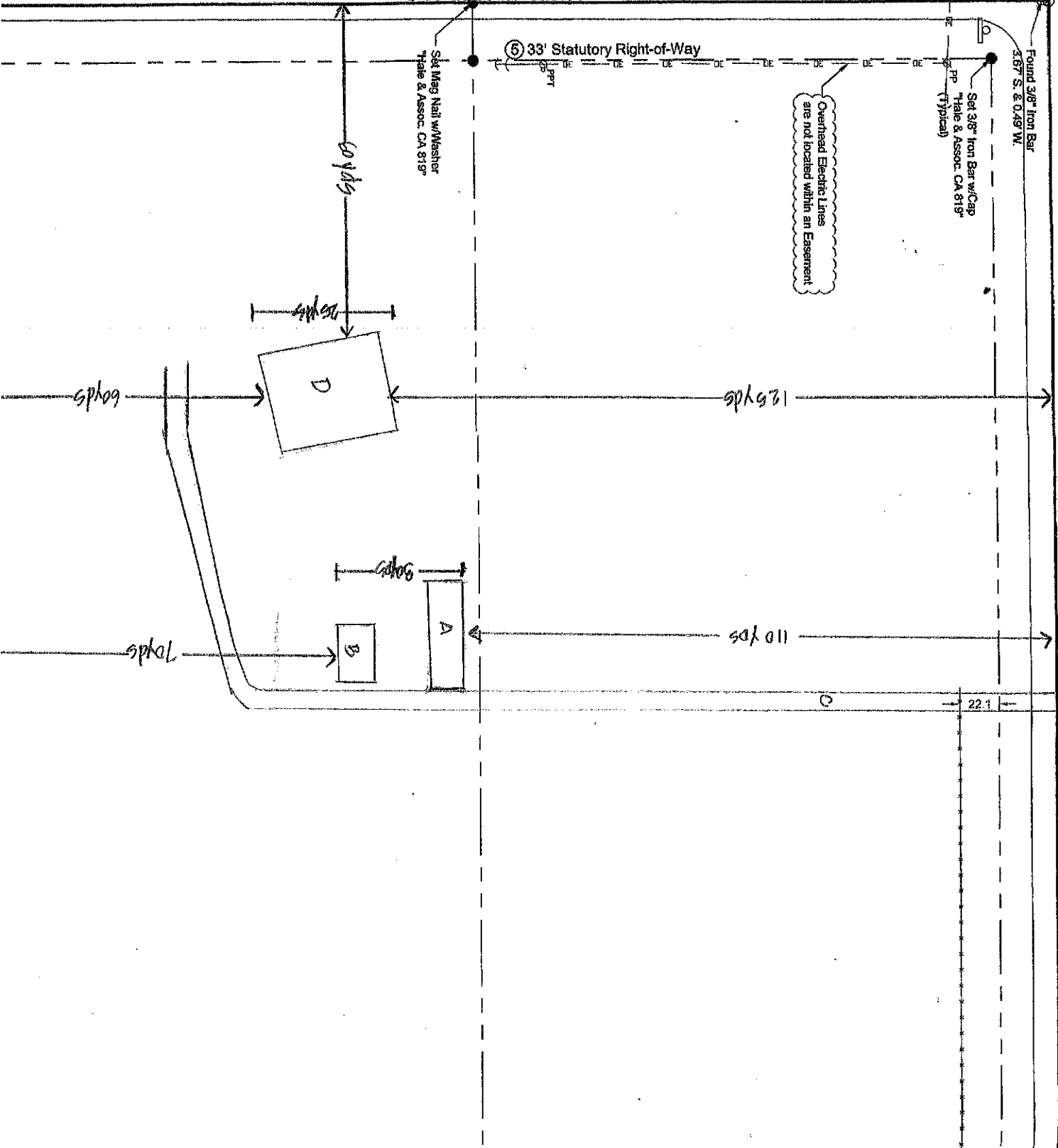

60 yds

126 yds

126 yds

90 yds

110 yds

70 yds

22.1

**RESIDENCE FOR:
 JANET & SCOTT MCCLAIN
 16150 E COFFEE CREEK ROAD, LUTHER, OK**

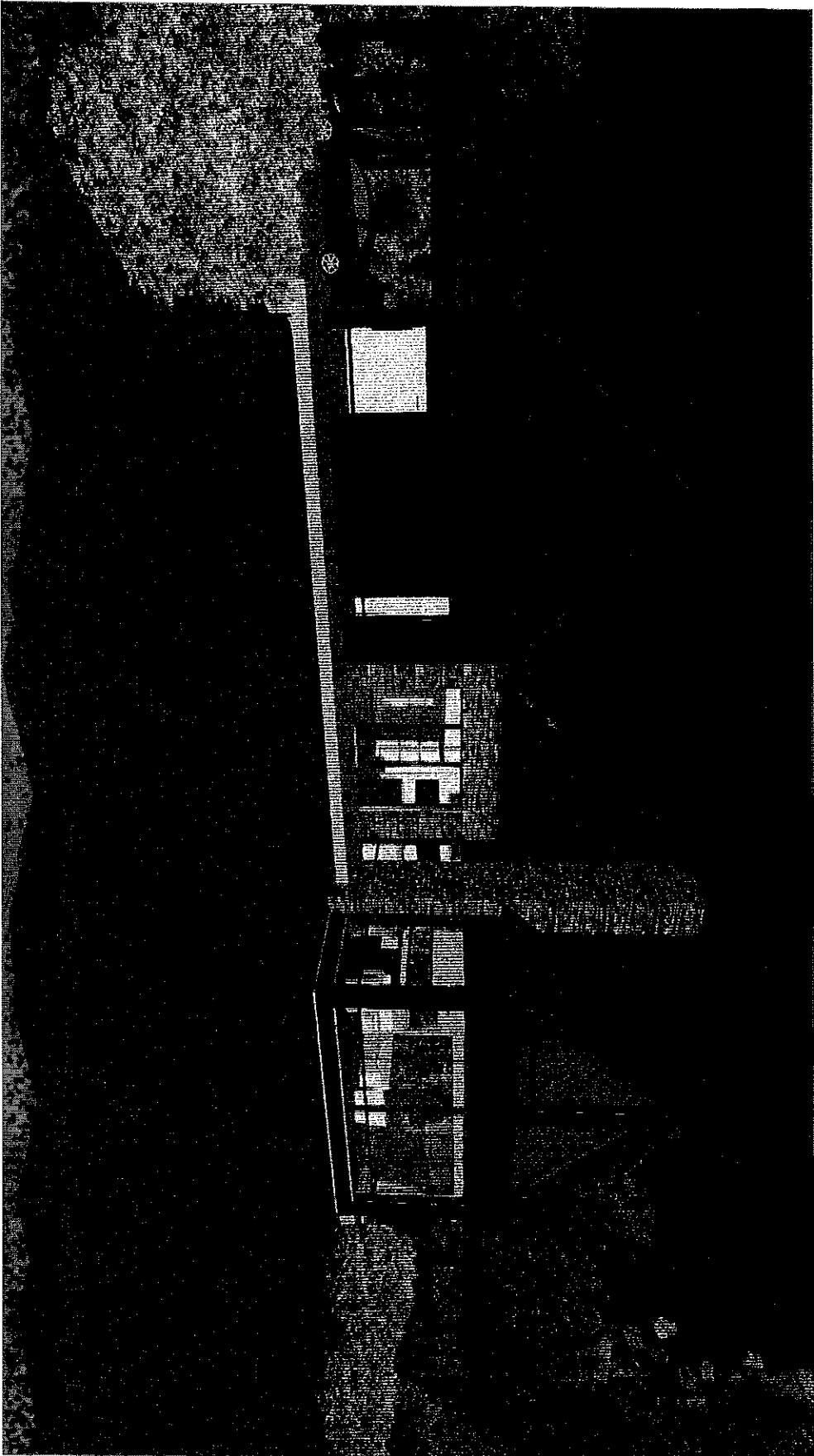

FRONT VIEW

SCHEMATIC DESIGN ONLY. VERIFY ALL DIMENSIONS, MATERIALS, FINISHES, EQUIPMENT PRIOR TO CONSTRUCTION



NO.	DESCRIPTION	BY	DATE

MCCLAIN RESIDENCE
 16150 E COFFEE CREEK ROAD
 LUTHER, OK

 ANDREW C. THOMAS
 ARCHITECT

ANDREW C. THOMAS ARCHITECT LLC
 1200 W. BILSHIRE SUITE 200
 OKLAHOMA CITY, OK
 73116

DATE:

8/24/2022

SCALE:

SHEET:

A-1

The flood map for the selected area is number **40109C0105H**, effective on **12/18/2009**

DYNAMIC MAP



MAP IMAGE



Changes to this FIRM ?

- Revisions (0)
- Amendments (2)
- Revalidations (0)

[Go To NFHL Viewer »](#)

You can choose a new flood map or move the location pin by selecting a different location on the locator map below or by entering a new location in the search field above. It may take a minute or more during peak hours to generate a dynamic FIRMette.



Esri, USDA Farm Service Agency, Microsoft

Approximate location based on user input and does not represent an authoritative property location

PIH

Without Base Flood Elevation (BFE) Zone A, V, AH, AV
With BFE or Depth
Regulatory Floodway Zone AE, AO, AH, AV, AR

SPECIAL FLOOD HAZARD AREAS

20.2 Cross Sections with 1% Annual Chance
17.5 Water Surface Elevation
Coastal Transect
Base Flood Elevation Line (BFE)

Powered by Esri



I want to...

Tools

LOT 1



RESOLUTION 2023-05R

TOWN OF LUTHER

**A RESOLUTION AUTHORIZING APPLICATION THROUGH THE ASSOCIATION OF
CENTRAL OKLAHOMA GOVERNMENTS (ACOG) FOR FINANCIAL ASSISTANCE
FROM THE RURAL ECONOMIC ACTION PLAN (REAP) FUND**

WHEREAS, the Town of Luther desires to seek funding from the Rural Economic Action Plan Fund for a Sewer Extension Project in the Delaporte Addition to provide additional sewer service to the residents of the Town of Luther and customers of the Luther Public Works Authority, and

WHEREAS, it is in the best interest of the residents of the Town of Luther to expedite the preparation and submission of an application for financial assistance from the Rural Economic Action Plan Fund in the form of a grant.

NOW THEREFORE BE IT RESOLVED, that Mayor William T. Arps of the Town of Luther is hereby authorized and directed to sign an application and related documents necessary to file and process a grant application through the Rural Economic Action Plan Fund on behalf of the Town of Luther.

PASSED AND APPROVED by the Town of Luther Board of Trustees this 10th day of October, 2023.

By: _____
William T. Arps, Mayor

ATTEST: _____
Scherrie Pidcock, Town Clerk

RESOLUTION 2023-06R

TOWN OF LUTHER

A RESOLUTION AUTHORIZING APPLICATION THROUGH THE ASSOCIATION OF
CENTRAL OKLAHOMA GOVERNMENTS (ACOG) FOR FINANCIAL ASSISTANCE
FROM THE RURAL ECONOMIC ACTION PLAN (REAP) FUND

WHEREAS, the Town of Luther desires to seek funding from the Rural Economic Action Plan Fund for a high-pressure sewer jet to provide more efficient sewer service to the residents of the Town of Luther and customers of the Luther Public Works Authority, and

WHEREAS, it is in the best interest of the residents of the Town of Luther to expedite the preparation and submission of an application for financial assistance from the Rural Economic Action Plan Fund in the form of a grant.

NOW THEREFORE BE IT RESOLVED, that Mayor William T. Arps of the Town of Luther is hereby authorized and directed to sign an application and related documents necessary to file and process a grant application through the Rural Economic Action Plan Fund on behalf of the Town of Luther.

PASSED AND APPROVED by the Town of Luther Board of Trustees this 10th day of October, 2023.

By: _____
William T. Arps, Mayor

ATTEST: _____
Scherrie Pidcock, Town Clerk